

Apsaros: A Roman Fort in Southwestern Georgia

Emzar Kakhidze

In southwestern Georgia, at modern Gonio, ancient Apsaros, 15 km to the south of the city of Batumi (Fig. 1) at a strategically important site, where the roads leading to the east (to Sebastopolis, modern Suchumi) and to the south (via the Čoroči River basin to Armenia Minor and Adjaristskali Gorge to eastern Georgia) join stands a rectangular fort (Figs. 2-3).¹ Its area covers 4.75 ha, with a length of 222 m and a width of 195 m. The total length of its walls' perimeter is 900 m, the height of the walls 5 m, and 7 m at the corners where towers were erected. The lower part of the walls is faced with large, dressed ashlar. The western wall has symmetrically arranged counterforts, while a later superstructure built of unworked stones is visible on its upper part. At present the fort has 18 towers, but originally it had 22. Four main towers stand at the corners of the walls, with stone stairs inside the fort. Formerly the fort had four entrances but today all but the western gate have been bricked up. To the east, the fort was protected by the mountains, to the north, by the river,

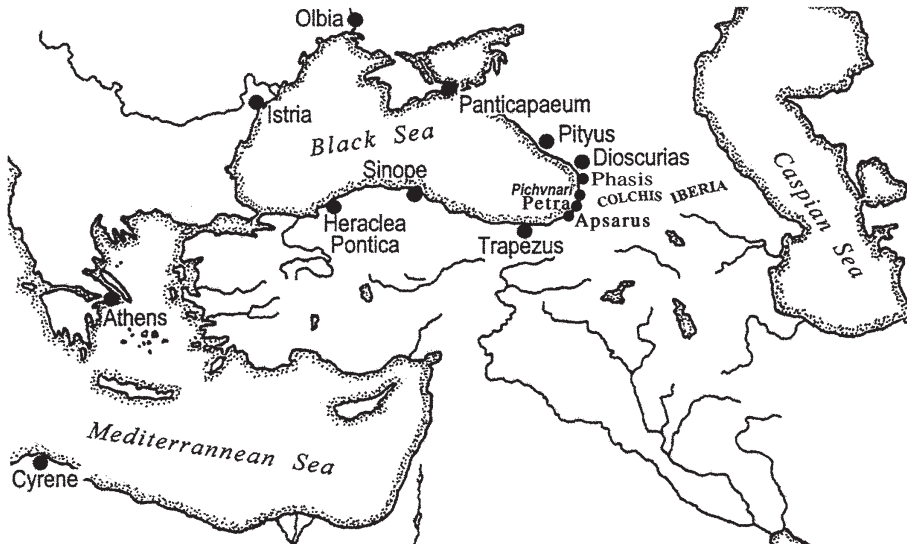

Fig. 1. Map of the eastern Mediterranean and the Black Sea.

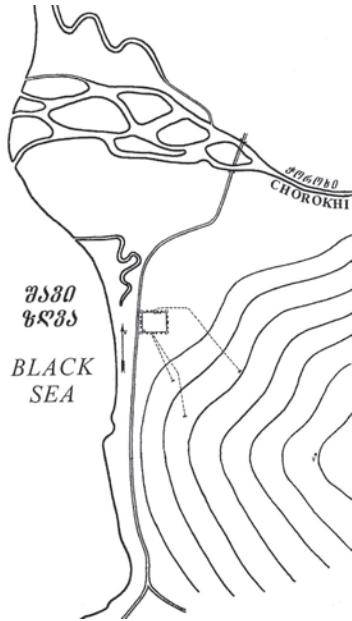

Fig. 2. Plan of Apsaros.

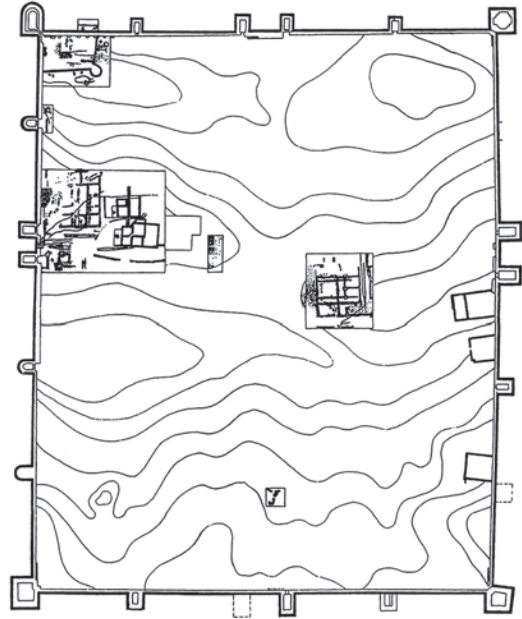

Fig. 3. Plan of Apsaros.



Fig. 4. Ruins of a bath, garrison mosque, sewage, water conduits, and cobblestone pavement.

while it was relatively unprotected to the south. This, no doubt, explains why the walls of the fort are mainly reinforced on this side. The ruins of a bath and the garrison mosque are preserved within the extant fort, as well as the sewers, water conduits and cobblestone pavement (Fig. 4).

The historical context

At first, at the end of the 1st and the beginning of the 2nd century AD, the Romans built temporary military camps of timber (*pila murilia*) on the Kolchian

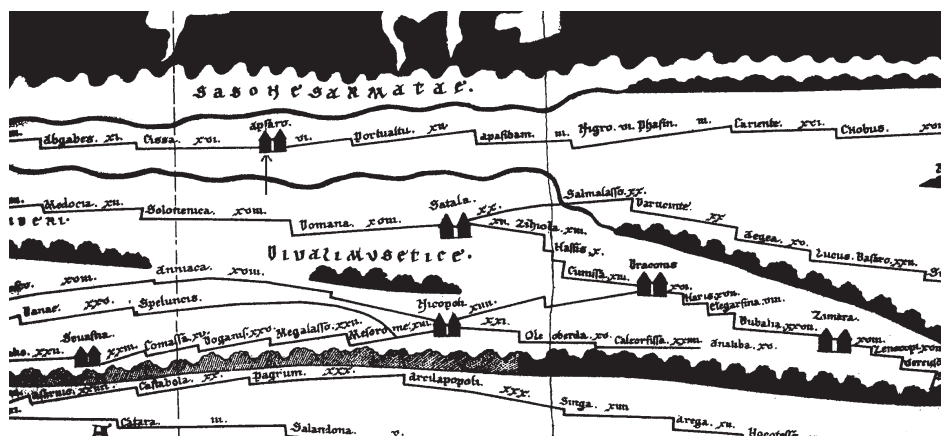

Fig. 5. Apsaros on the Peutinger Table.

littoral (for example the original Phasis described by Arrian in *Periplus* 9).² Probably, the *castella murata* in Apsaros was built earlier.³ Unfortunately, the architecture of this fort (Figs. 6-9) is not completely understood and therefore our knowledge is incomplete. According to V. Lekvinadze, the oldest structures brought to light to date are datable to the Roman period (large ashlars).



Figs. 6-9. Apsaros fort.

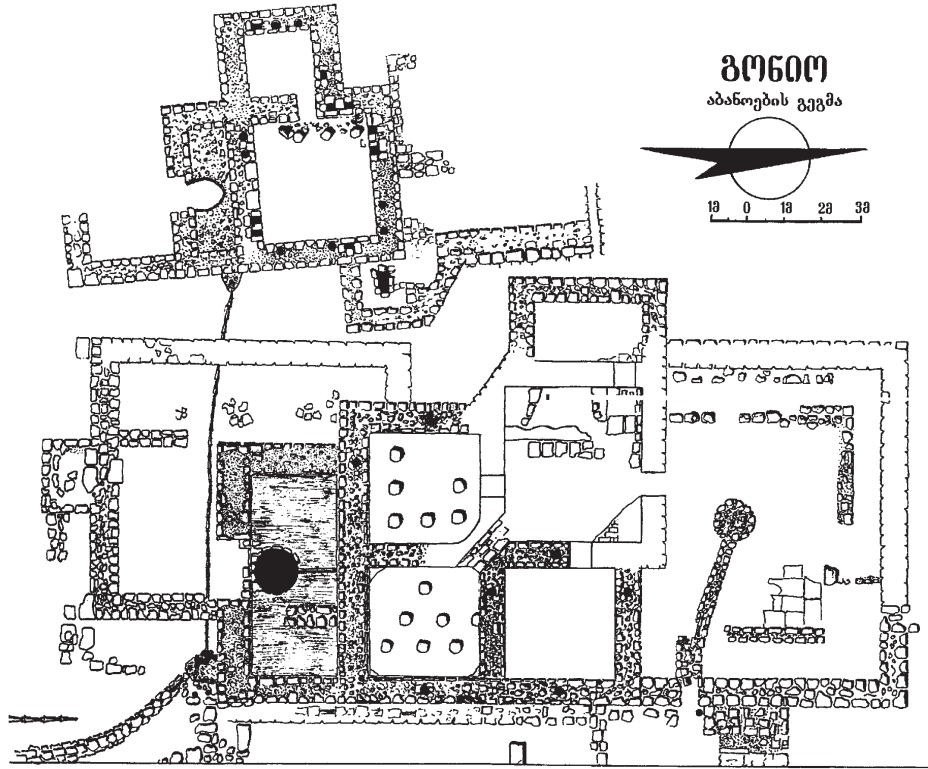

Fig. 10. Plan of bath house.

The walls built of rubble stones and bricks must be from Byzantine times, while the merlons were added during Ottoman dominance.⁴ Some scholars suggest that Apsaros may easily be compared with the early Byzantine forts.⁵ According to ancient sources and especially archaeological data (see further below), the fort was not in use for about 250 years (from the 4th century to the early half of the 6th century AD). During the period of the Byzantine-Iranian War and afterwards, the importance of Apsaros was greatly reduced, and it seems that it had become absolutely impossible to rebuild such a strong fortification.⁶ The only possible exception may be the restoration of the fort after the Boranis' invasions of the east coast of the Black Sea during either the second half of the 3rd century or the beginning of 4th century,⁷ but this point of view needs further examination.

Despite the fact that Caucasus was routed by the Roman commander Pompey as early as 65 BC,⁸ it was only after Nero's increased concentration of Roman military forces in the East⁹ that a special so-called "Pontic Limes"¹⁰ or Pontos-Caucasian frontier¹¹ was formed. This was done in order to reinforce Roman positions in southern Caucasus and to control the region of northern Caucasus.¹²

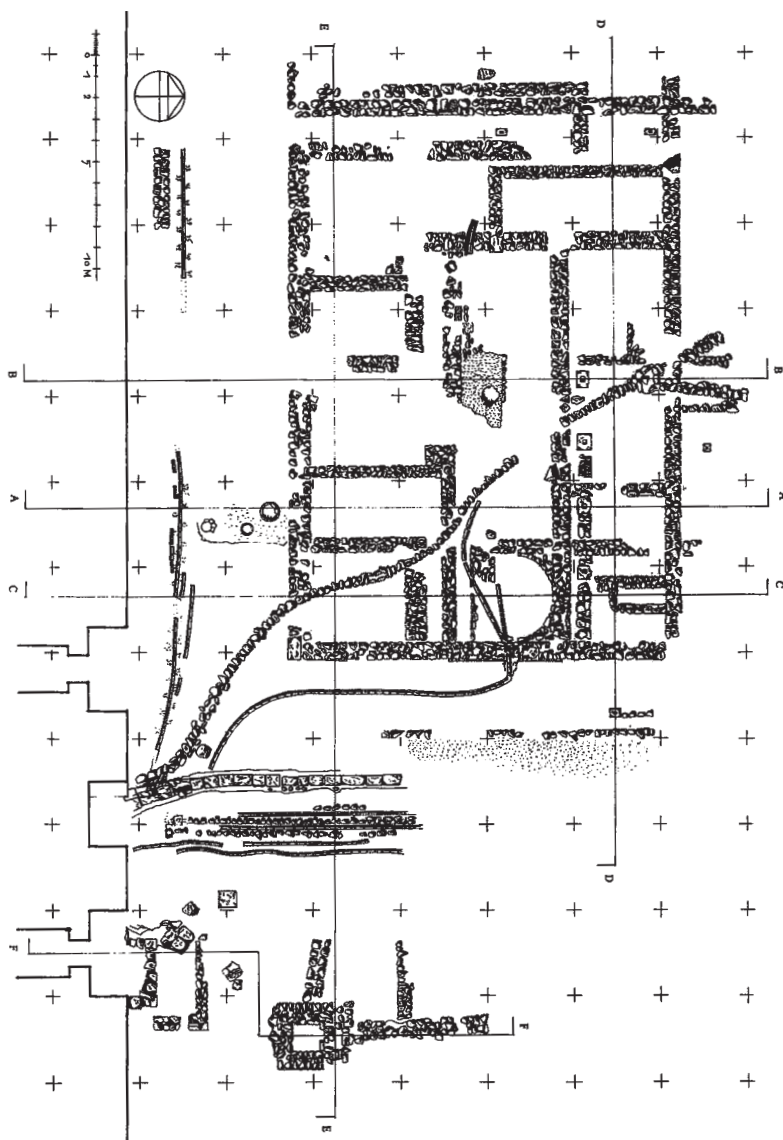

Fig. 11. Plan of the barracks.

The main reason for such actions was Nero's intention of sending his troops on an expedition to northern Caucasus (for this purpose *Legio I Italica* and the Rhine frontier élite *Legio XVI Gemina* were formed¹³). This, at first sight, adventurous idea served a rather more serious purpose. Nero wanted not only to repeat the deeds of the past and indeed to surpass them, he also, and perhaps most importantly, had particular geo-strategic interests. He knew that the territory of Caucasus offered an important passage connecting the Empire with

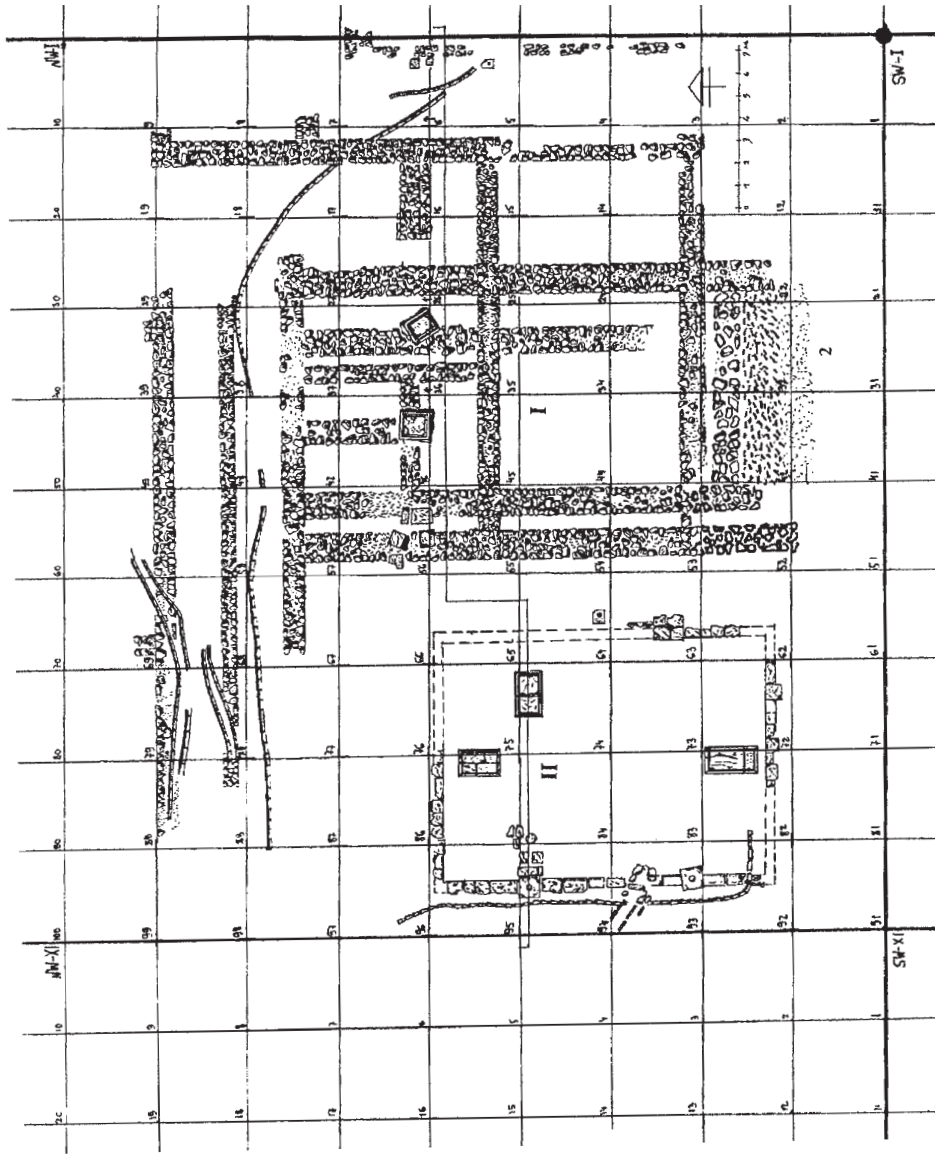

Fig. 12. Plan of the principia.

India.¹⁴ Despite some not quite successful actions, Rome had actually managed to establish a number of very important footholds in the region that allowed her to control the eastern part of southern Caucasus and ensured reliable communication with Bosphoros where dangerous movements of the nomads had already begun.¹⁵ The Roman Empire's power was further institutionalized at the time of Vespasian and Titus. This brought a new wave of expansionistic foreign policy distinctively aimed towards the East. Roman aggression was, of



Fig. 13. Sewers and water supply of the Roman, Byzantine, and Ottoman periods.

course, met with resistance. The local population of Trapezous, for example, withstood Roman advances in AD 69 (Tac. *Hist.* 3.47-48). At the same time, the situation was also rather tense in the mountainous areas close to Apsaros (Arr. *Periplus* 15). The problem of the Alani was serious, and the related factor

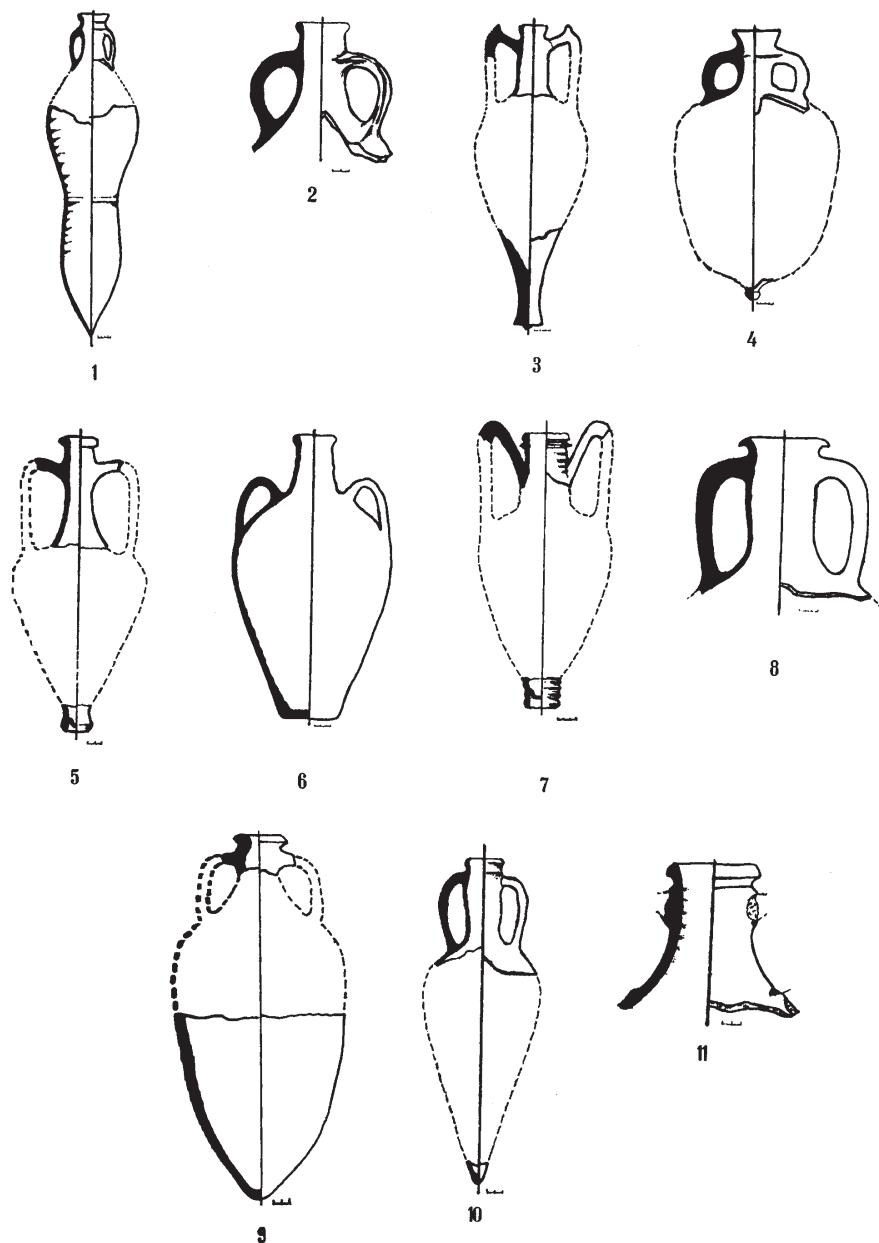

Fig. 14. Amphoras.

of the eastern Georgian state (Iberia) was also an issue, the latter methodically moving towards the sea.¹⁶ Rome had actually lost Armenia and because of this it became necessary to concentrate more troops along the frontier territories not only of Armenia Maior and Syria but along the whole eastern frontier (Tac. *Ann.*, 2.6; *Hist.* 3.47; Jos. Flav. *Bel. Jud.* 7.220-222, 230-233; Suet. *Nero* 18,

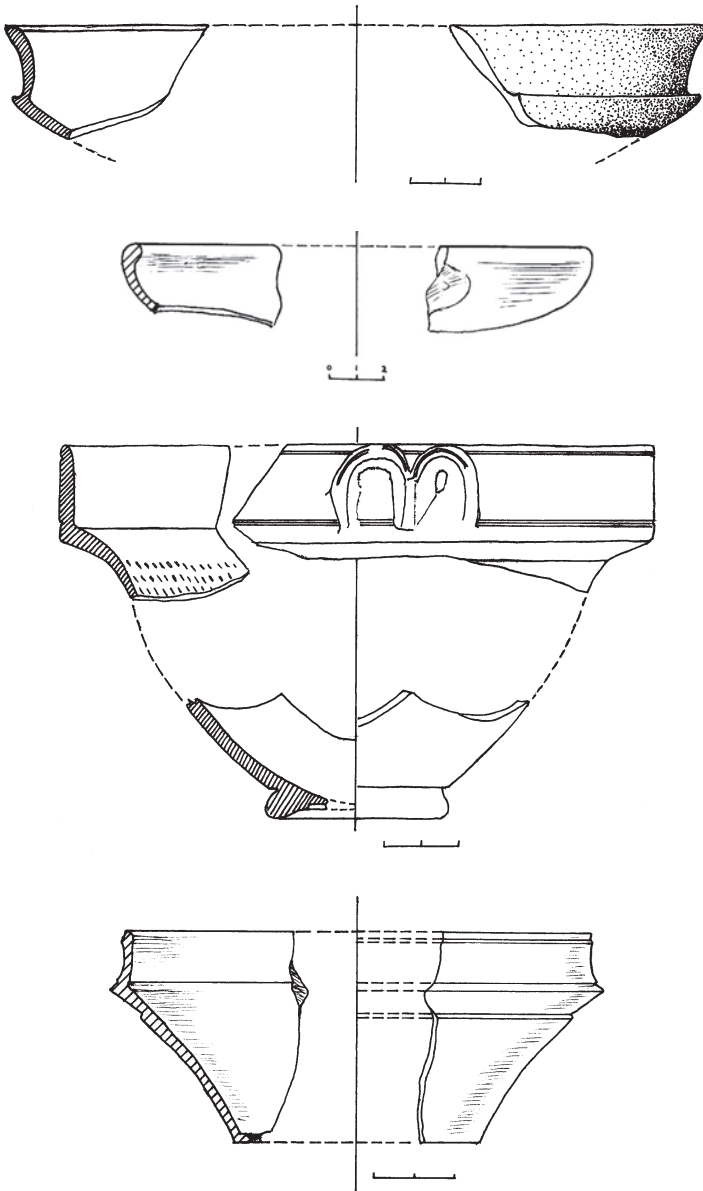

Fig. 15. Red-glazed bowls.

Vesp. 8. 4). This was followed by the establishment of strong military bases at Trapezous, Hyssiporto, Apsaros, Phasis, Sebastopolis and Pityous.¹⁷

According to Plinius (*NH* 6. 12), Apsaros was a functioning fort already in the 70s AD,¹⁸ which is confirmed by archaeological evidence as well. Copper coins struck in the names of Tiberius, Nero, Vespasian and Domitian

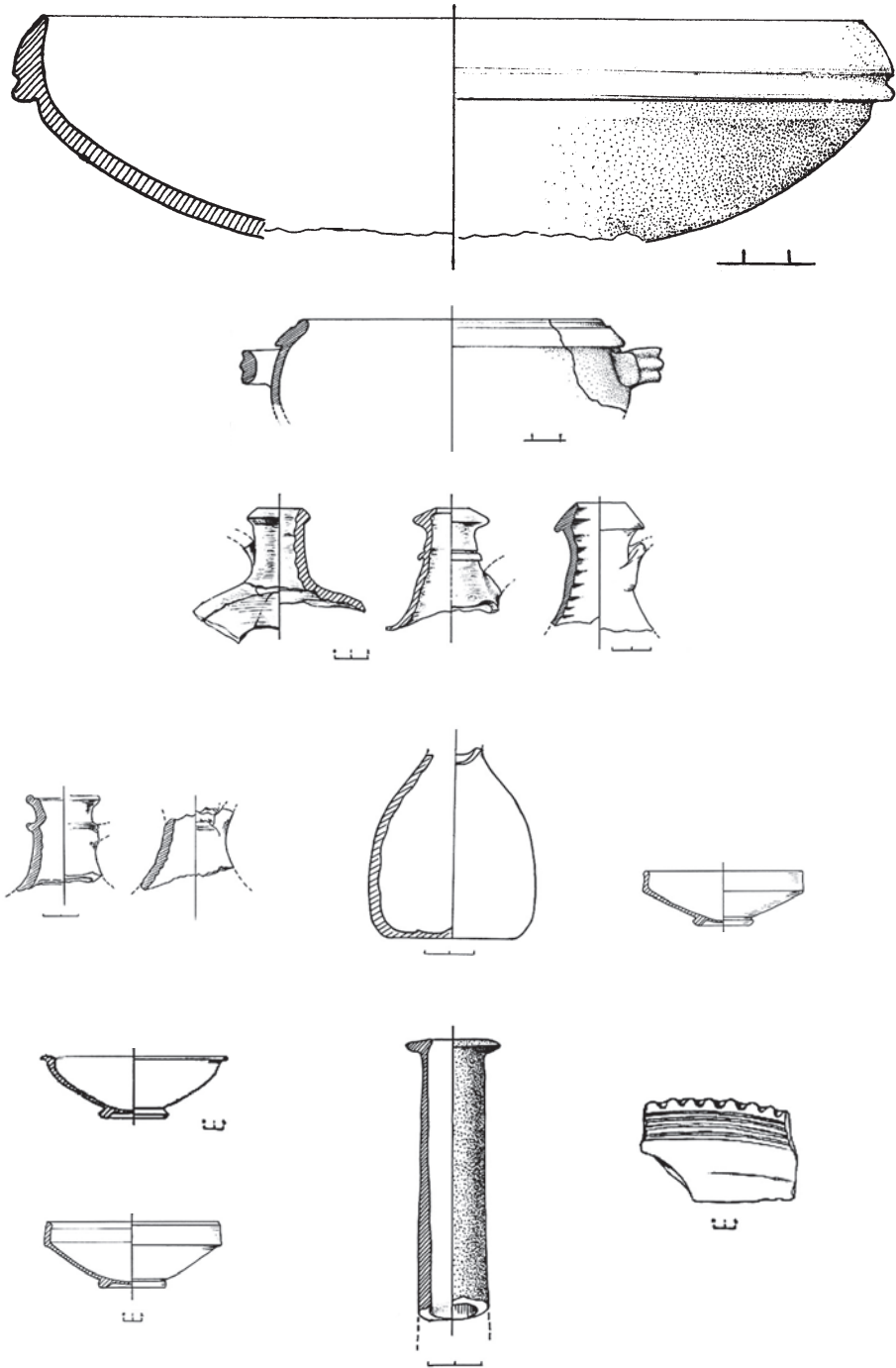

Fig. 15. Red-glazed bowls.

(Fig. 26.1)¹⁹ have been discovered here, as well as amphorae from the 1st century AD believed to have been produced in Italy (Fig. 14.3) and Kos,²⁰ dummy-handled red-glazed bowls (Fig. 15.1-2),²¹ Sinopean *louteria* D (Fig. 23),²² glass vessel (Figs. 16, 17.1, 17.3-4),²³ etc.

In AD 132 Arrian, the governor of Cappadocia, traveled the Black Sea coast. He mentions five cohorts (*speira*) stationed in Apsaros (*Periplus* 6). They were without doubt auxiliary units.²⁴ Incidentally, a garrison of this size²⁵ could be found only in a couple of *castella* on the Black Sea shore; only 400 élite soldiers were stationed in Phasis (Arr. *Periplus* 9) and just 20 horsemen in Hyssiporto, modern Canayeri, 26 km east of Trapezous (Arr. *Periplus* 7). This situation seems to be accounted for by the expansion of Iberia to the Black Sea littoral. This process of expansion was brought to fruition by the Zydritae, loyal to Pharasmanes II, King of Iberia.²⁶ Other sources also report on the Roman garrison at Apsaros. Thus, according to an inscription (*ILS* 2660) found at Abella, Italy, Marcius Plaetorius Celer, decorated by Trajan for his participation in the Parthian war (113-117), had *praepositus numerorum tendentium in Ponto Absaro*.²⁷ Another important piece of evidence is a fragment of a 2nd century AD papyrus written by a veteran of Apsaros and discovered in Fayum, Egypt. The papyrus refers to the veteran Martial who had served in the *cohors II Claudiana* and was stationed at Apsaros.²⁸ Along with this evidence the deployment of that particular cohort at Apsaros is confirmed by a tile discovered in 1995 with a 2nd century Latin inscription (Fig. 19).²⁹ According to another tile (Fig. 20) and an Italic bronze tripod lamp (Fig. 21) with Latin inscriptions we may consider that both *cohors sagittarii* and *cohors Aurelia* might have been stationed there in 2nd century.³⁰

The 3rd century AD may be considered a turning point in the history of Apsaros. In the mid-250s the Boranoi gained access to the Black Sea by way of the Crimea.³¹ Zosimus tells of the raids of the barbarians on the Kolchian littoral in the mid-3rd century (*Hist. Nova* 1.31-33). Historical sources say nothing about the destruction of Apsaros at the time, but observations of the stratigraphy of the fort site show that at the turn of the 4th century the fort temporarily ceased functioning. The cultural layers of this period bear traces of destruction.³²

From the end of the 3rd century AD the centre of the Roman Empire gradually shifted to the East. Thanks to Constantine the Great, the Romans managed to strengthen their positions in the eastern part of the Black Sea (Zos. *Hist. Nova* 2.33). They, supposedly, stationed their garrisons at Apsaros as well. Lack of archaeological data warns us to be careful here. Hypothetically there could have been some fundamental changes in the 340s AD because Lazica, modern western Georgia, became more powerful.³³ Apparently, in order to neutralize the increasing strength of Lazica, the Romans gave preference to Tsikhisdziri, located nearer to the centre of the Lazica-Rioni River area.³⁴ Significantly enough, the 4th century sources (Sophronius, Dorotheos of Tyre and Epiphanius of Cyprus) describe the considerably remote developments

in relation to Apsaros.³⁵ In more reliable sources, e.g. the *Res Gestae* by Amianus Marcellinus, nothing is said about Apsaros in the description of the Black Sea littoral, whereas Phasis and Dioskourias (Sebastopolis) are named as towns (22.8.24). Nor can Apsaros be found in *Notitia Dignitatum*, where Roman military units and their deployment in *Dux Armenia* are mentioned (*Or.* 38).³⁶ Certainly, an anonymous source repeats Arrian's text word for word, but he has obviously used additional sources. Thus, he refers to Apsaros as well as Kordylon and Athenai as a village (*Periplus* 40). According to the *Life of Daniel the Stylite* the borders of Lazica shifted to Hopa to the south of Apsaros in the 460s-470s.³⁷ It cannot be ruled out that Apsaros and its surrounding territories was within Iberia during the reign of Vachtang Gorgasali (second half of the 5th century AD) and his successors.³⁸ According to Procopius, the Byzantines found Apsaros and Phasis entirely devastated in the 540s (*De bello Gothico* 8.2.12-14). In his other work (*De Aedificiis*, 560), Procopius makes no mention of Apsaros. It is not accidental either that the same author, as well as Stephanos Byzantios (s.v. Ἀψούριδες), mainly speak about the past of Apsaros. Thus, Justinian's novels list the cities and forts in Lazica and the Pontus Polemoniacus (*Jus. Nov.* 31), among which one cannot find Apsaros.

The archaeological evidence

Archaeological data also support the evidence preserved in our written sources. Almost none of the specimens of the numerous *terra sigillata* vessels found in Apsaros are decorated with relief ornaments, whereas normally this kind of pottery is lavishly ornamented with relief, geometric and floral motifs in the 4th and especially 5th centuries. Unlike Tsikhisdziri and Pičvnari not a single fragment of so-called blue-spot glass is found here. This glass type appears in the latter half of the 4th century and continues into the early 5th century. Neither have fragments of 4th-5th century Sinopean amphorae with conical bodies been found whereas there are many specimens from this production centre dated to the 2nd-3rd and 6th centuries AD in Apsaros. Not a single coin among the rich numismatic material found here is dated to the second half of the 4th, the 5th or the first quarter of the 6th century. In the stratigraphy of the fort, in particular, between the cultural layers of the Roman and the Byzantine periods, a 20-25 cm sterile stratum is discernible, which must have been formed in the 4th-5th centuries.³⁹

As is well known, the ruling class of Lazica, and even Iberia was not much interested in communication by sea but was instead preoccupied with strengthening the fortifications of the hinterland. That is why the fort at Apsaros was deserted from the latter half of the 4th until the early half of the 6th centuries AD, and why Procopius found Apsaros totally destroyed.

During the excavations rich material from the 1st-3rd century AD was found. Particularly diverse are the ceramics, although amphorae constitute about 80 % of the pottery. Several types of imported amphorae (Fig. 14.3-11)

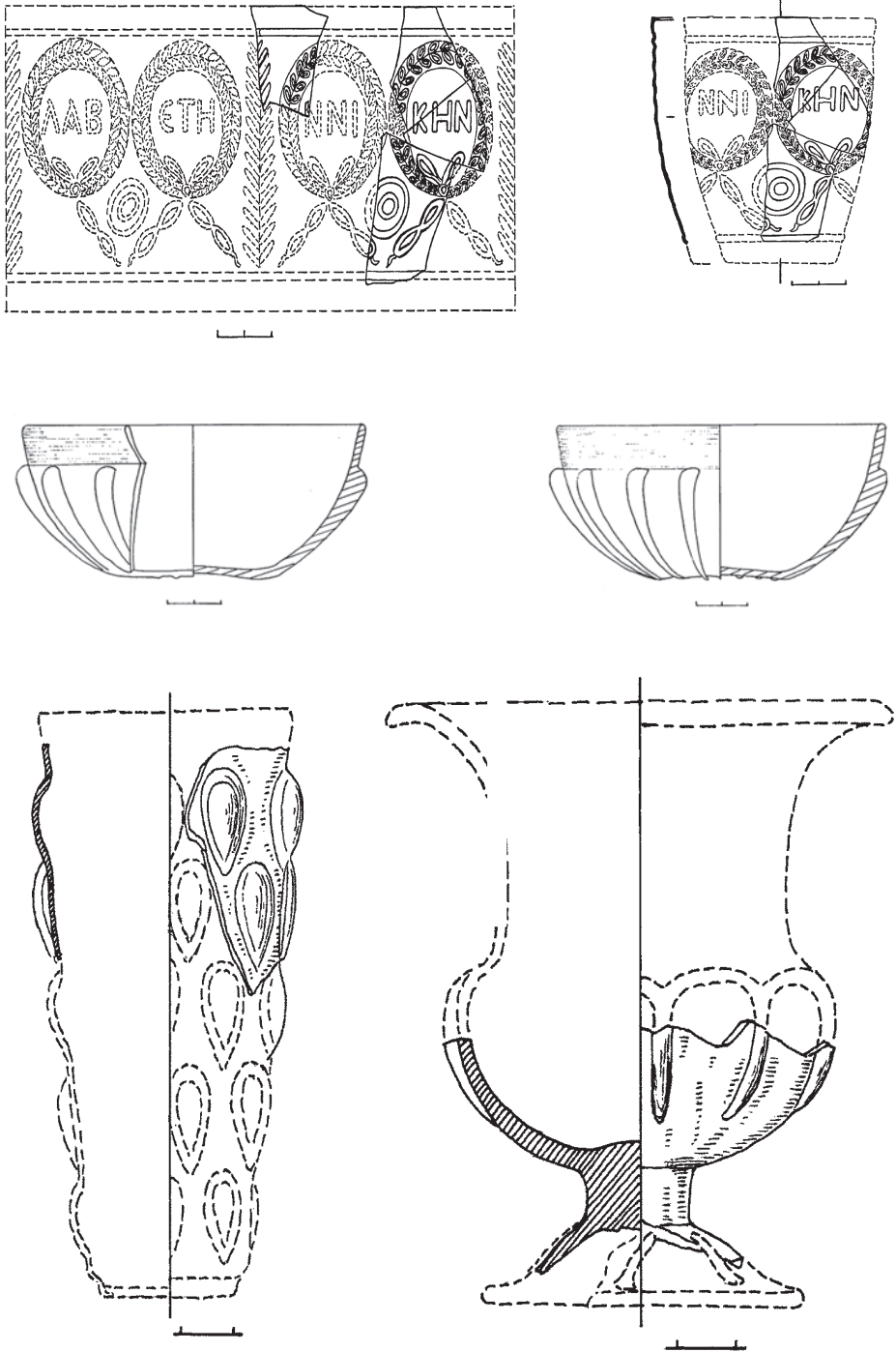

Fig. 16. Glass vessels.

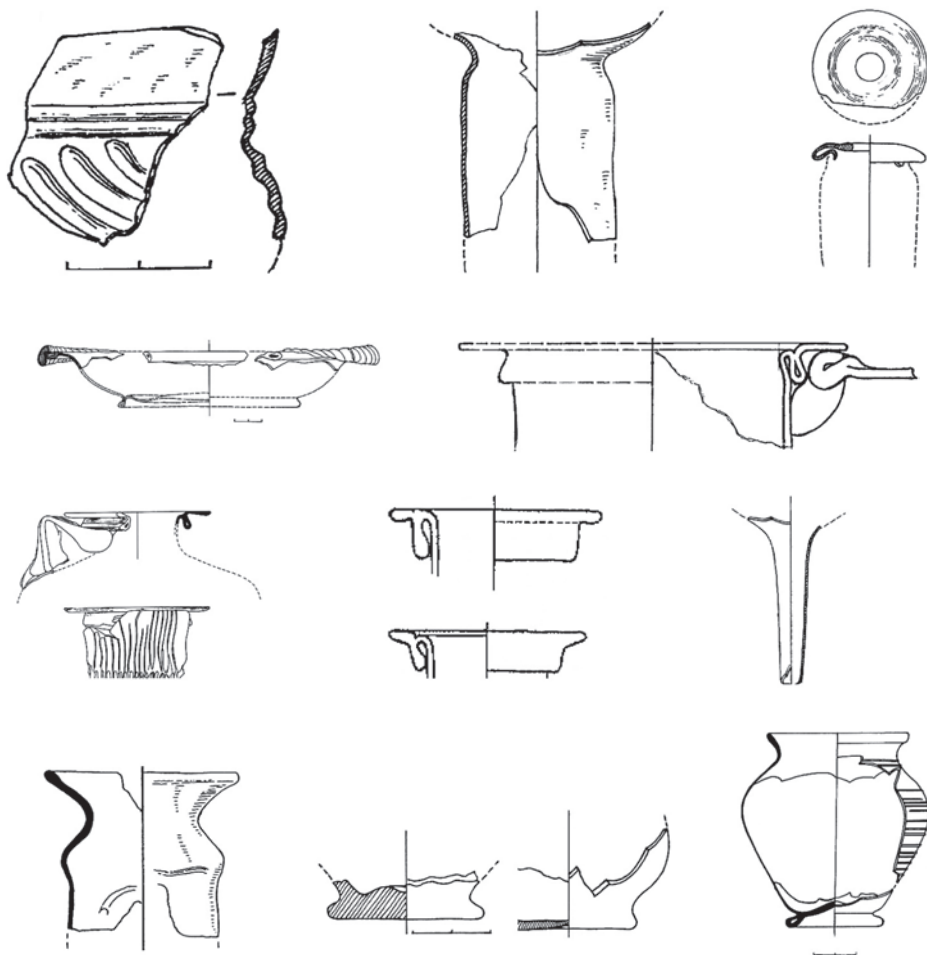

Fig. 17. Glass vessels.

as well as *terra sigillata* (Fig. 15) from this period can be singled out and are mainly products from the southern Black Sea region and the Mediterranean.⁴⁰ The same applies to numismatic finds (coins of Agrippa I, Tiberius, Nero (Fig. 26.1), Vespasian, Domitian, Trajan (Fig. 26.2-3), Hadrian (Fig. 26.4-5), Antoninus Pius and Faustina, Septimius Severus, Commodus (Fig. 26.6), Gordian III and Tranquilina, as well as Aurelian),⁴¹ glass ware (Figs. 16-17),⁴² tiles (Figs. 19-20), lamps (Figs. 21-22), *louteria* (Figs. 23-25),⁴³ a cosmetic instrument of bone with dot-ornament, terracotta (Fig. 27), statue, antefix, various tools (Fig. 28), stone bullets (Fig. 29), stoppers (Fig. 30), ink-wells (Fig. 31), etc.⁴⁴ A particularly rich hoard dated to the first centuries AD was discovered in 1974 during road construction on a slope near the Gonio fort (Fig. 18).⁴⁵

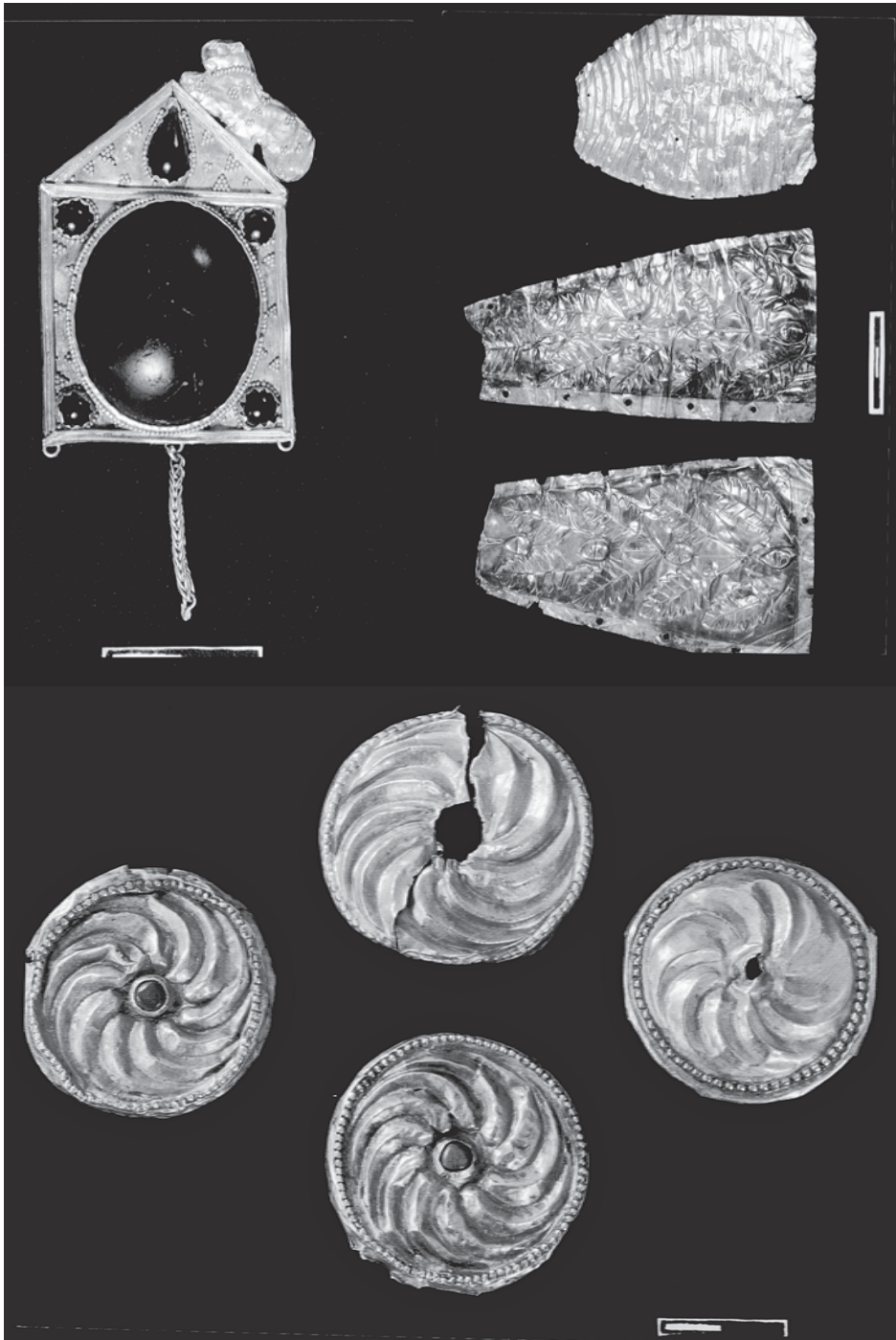

Fig. 18. Hoard from Gonio.

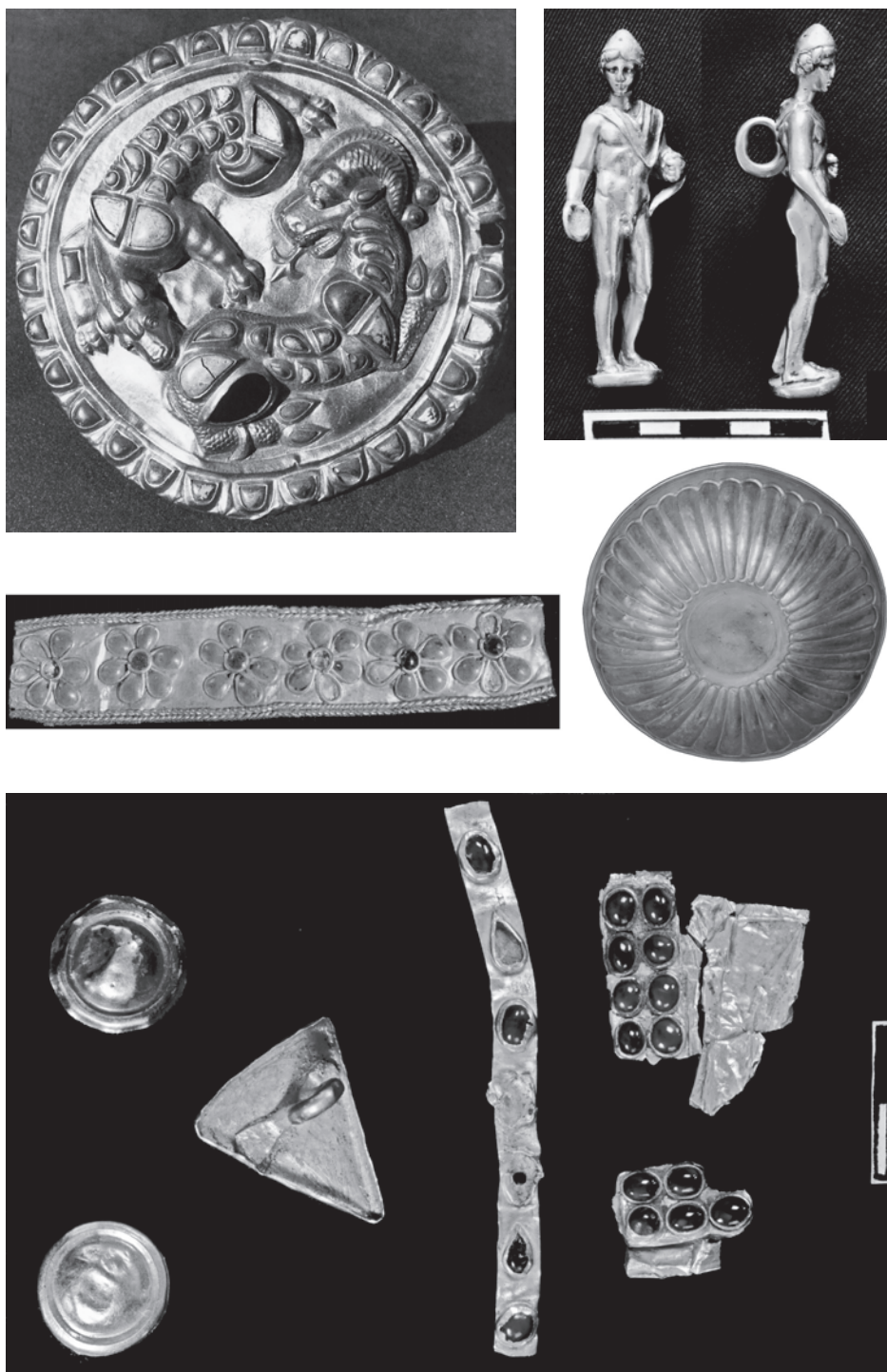

Fig. 18. Hoard from Gonio.

Remains of two bath-houses (the so-called *Kastellbaden*) were discovered at the southern gate of the fort. One bath was of small size. It had only a boiler room and sections for hot water. The other bath-house is more monumental in scale, probably designed for the soldiers. Four sections (the *caldarium*, *tepidarium*, *frigidarium* and *apodyterium*) were excavated here (Fig. 10). Close to the baths stood the remains of a barrack. The walls were built of fine-cut stones using clay mortar. The excavations revealed stone bases with quadrangular holes to accommodate timber columns (Fig. 11). Close to the northern wall the remains of a presumed *principia* have been identified. So far, part of the walls and the foundation have been identified (Fig. 12). Wooden structures seem to have prevailed in the interior architecture of the fort, stone being used mainly for the foundation and, occasionally, the ground floor.⁴⁶

A quadrangular water cistern from the Roman period was discovered in the western section of the southern wall of the fort. The water system was connected with the cistern by clay pipes and a stone distributor. A well was found here as well. Various systems of sewerage and water supply from the Roman, Byzantine and Ottoman periods were discovered here, too (Fig. 13). In 1997 the remains of an amphora kiln from the 2nd-3rd centuries (Fig. 32) were also found in the south-western corner of the inner fort.⁴⁷

Unlike what is true of the era of Greek colonization and the Hellenistic period there are no obvious signs of mutual influences. Only two types of local amphorae from the second half of the 2nd century and the first half of the 3rd century AD were discovered in the fort (Fig. 14.1-2).⁴⁸ Sometimes local brown-clay specimens imitating Sinopean *louteria* are also encountered in the cultural layers of the end of the 2nd century and the 3rd century AD (Fig. 34).⁴⁹ Some other types of contemporary pottery confirm the establishment of a use of foreign shapes in local craftsmanship (Fig. 33).⁵⁰ Unlike earlier periods, Roman civilization never reached the hinterland.

A large number of imported pieces, dated to the end of the 1st to the beginning of the 2nd centuries AD (Figs. 14.3, 15.1-2, 16, 17.1, 3-4), have been found at Apsaros. This is in contrast to the other Roman forts unearthed in Kolchis, as the Apsaros garrison did not have close contacts with the local communities. Such products were mostly used by the Roman military units. Typical Roman *canabae* were not introduced here or in other forts.⁵¹ No im-



Fig. 19. Tile with Latin inscription.

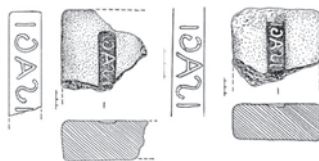

Fig. 20. Tiles with Latin inscription.



Fig. 21. Bronze tripod with Latin inscription.

ported goods have been found in the surroundings of the fort, apart from a small hoard from Satechia and one glass vessel from Zanaqidzebi (Fig. 35). Imported goods (mainly products from Asia Minor) from the 2nd century are frequent finds in the Kolchian coastal areas where the Romans established their bases at strategically important sites, first of all in Trapezous.⁵²

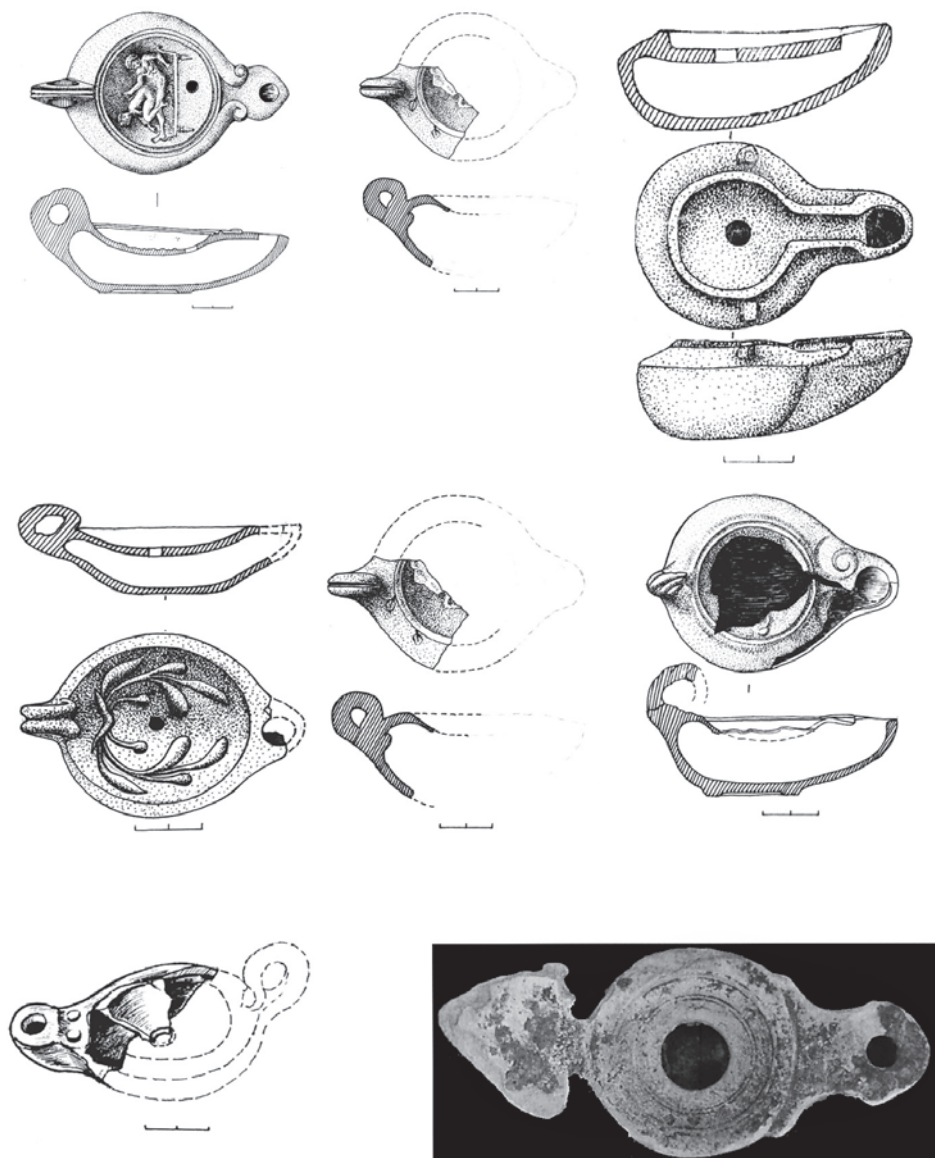

Fig. 22. Lamps.

From the archaeological material from other sites in western Georgia we might suppose that Roman influence could be observed in these sites' economic spheres (e.g. the production of ceramics, weaponry, tools, jewelry, and building construction). From the 2nd and especially from the 3rd century AD goods were imported abundantly and distributed to the inner or/and high-

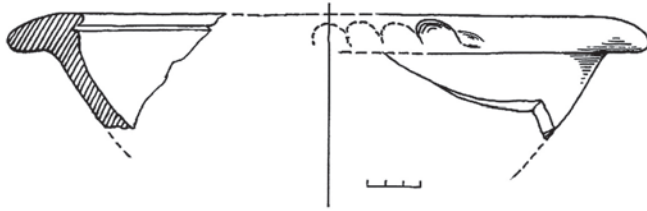

Fig. 23. Louterion.

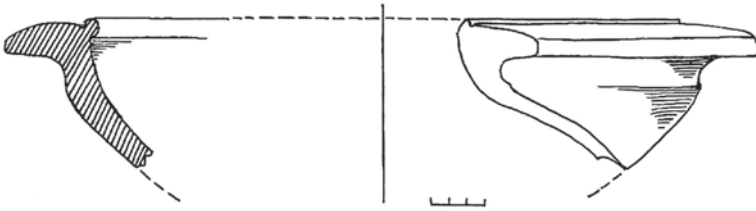

Fig. 24. Louterion.

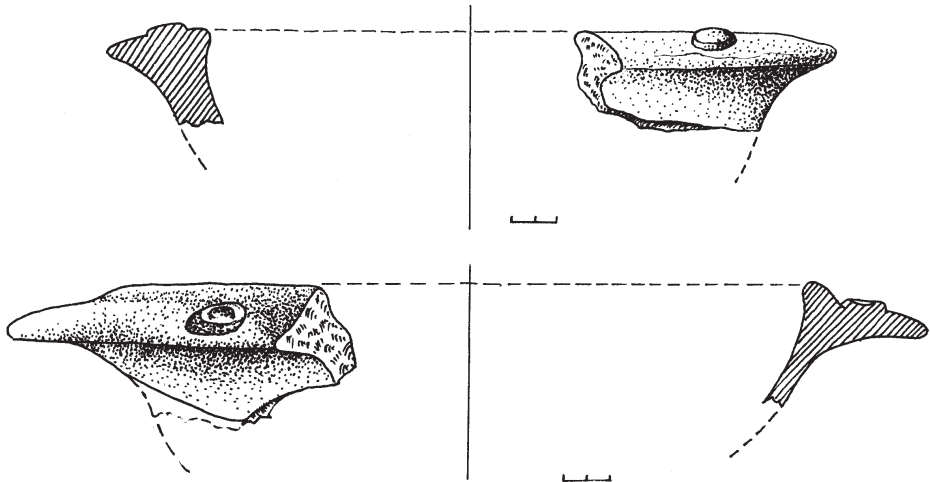

Fig. 25. Louteria.

land regions.⁵³ Elements of Roman culture also start to appear around forts in the coastal settlements (e.g. new customs and habits in burial practices and religious beliefs). Romanization, however, as known from other provinces of the Roman Empire, cannot be observed. In contrast to the 1st-3rd century, a tendency towards uniting “Western” and Georgian beliefs and cults is observed, although this trend was not adopted by the general public.⁵⁴

In general, Roman forts can be seen as stabilizers, which somehow even precipitated the process of “urbanization” in Lazica. Roman gover-



Fig. 26. Roman coins.



Fig. 27. Terracotta.

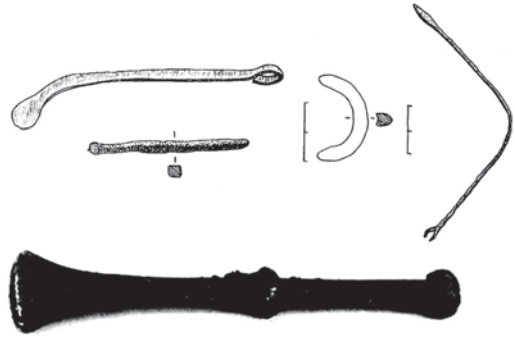

Fig. 28. Tools.

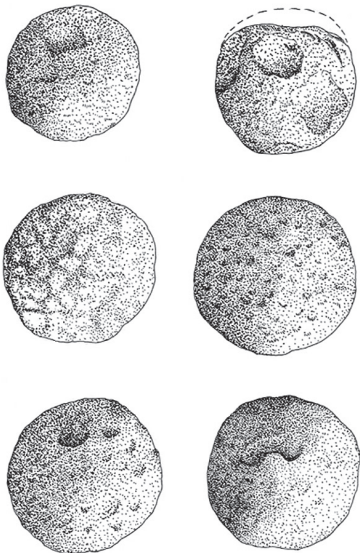

Fig. 29. Stone bullets.

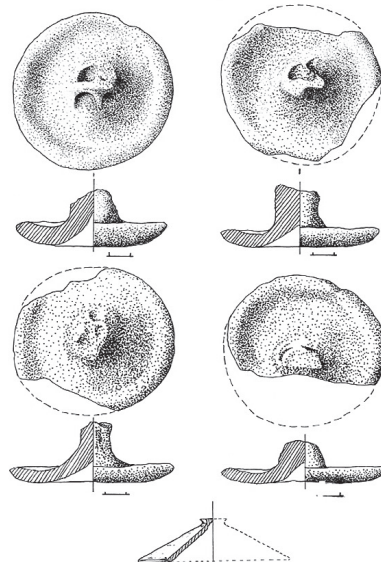

Fig. 30. Stoppers.

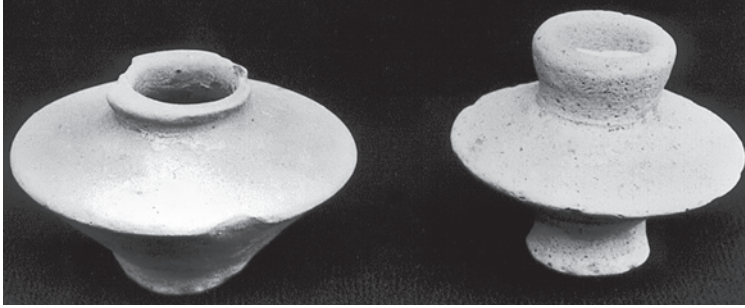

Fig. 31.
Ink-wells.

nance consolidated the political situation in the region.⁵⁵ A very important result of Georgia's relations with the Roman world was its Christianization. At the dawn of the new era Southern Caucasus was compelled to join in all the global historical processes against its will and this was followed by many significant changes. Of course, it was rather more convenient to follow the new religion within the boundaries of the Empire. It is interesting that according to Sophronius (4th century AD), the Apostle Matthias, who was chosen in place of Judas, died in Apsaros and was buried there.⁵⁶ Soon after AD 300 two associates of Orentius, a military official martyred for Christianity, died in this fort as well.⁵⁷

The excavations in Gonio-Apsaros are still ongoing and the study of the outside strata of the fort (Fig. 36) will further enlighten our knowledge of the monument.

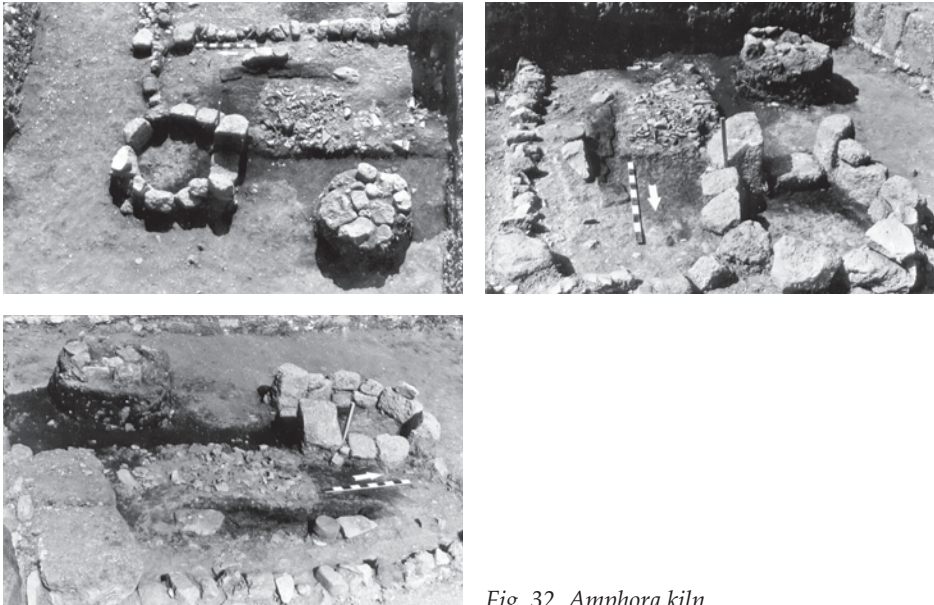

Fig. 32. Amphora kiln.

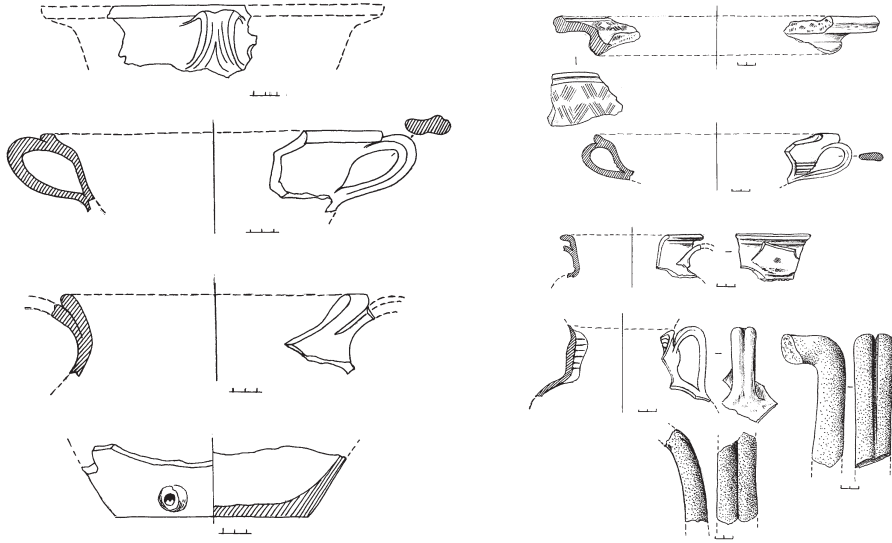

Fig. 33. Cooking pots.

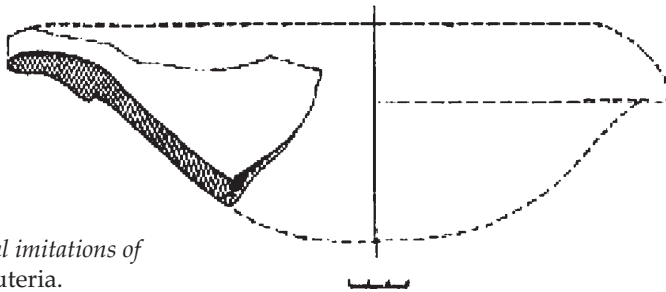

Fig. 34. Local imitations of Sinopean louteria.

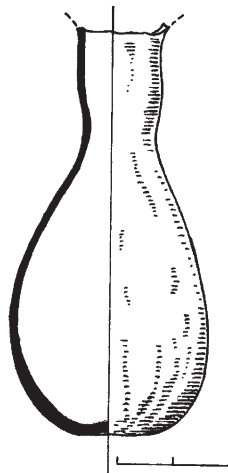

Fig. 35. Glass vessel from Zanaqidzebi.



Fig. 36. Strata outside the fort.

Notes

- 1 On the identification of Apsaros with the fort in Gonio, see Plontke-Lüning 2003, 7, 10; 2005, 133, no. 1.
- 2 Persians too erected a wooden defensive wall in the hinterlands in Kotais (Proc. *De bello Gothico* 8.16.16-17) in AD 551, during the war with Byzantium in Lazica (i.e. Kolchis, modern western Georgia).
- 3 Unlike other contemporary forts in the region, we find not only the name of the fort of Apsaros but also a sketch of it on the Peutinger Table (10.5) (Fig. 5; Miller 1916, 636-638). As is known, Castorius used old sources, viz. those of the

- 1st -2nd century AD (Bryer & Winfield 1985, 346; cf. Plontke-Lüning 2005, 134; Gamkrelidze & Todua 2006, 94).
- 4 Lekvinadze 1961, 225-242; on the architecture in English, see Gregory 1997, 21-25; in German, see Plontke-Lüning 2003, 13-14; 2003, 30-31; 2005, 138.
 - 5 Mitford 1974, 16319; Džaparidze 1998, 46; 2000, 41-42.
 - 6 The revival of Apsaros in the first half of the 6th century AD was prevented by the shift of the Byzantine border to the north of Batumi to modern Tsikhisdziri where the fortified city of Petra was built on Justinian's orders (*Jus. Nov.* 31) following the conclusion of a "permanent peace" treaty (AD 532) with Iran. In the mid-6th century the Byzantines demolished the stronghold of Petra (Agathias 5.1-2) and, probably restored Apsaros, beginning with the south wall (Figs. 5 and 7). The strata of the Byzantine period, however, are hardly discernible in the fort and absolutely invisible outside of it (Kakhidze et al. 2002a, 52; 2002b, 262).
 - 7 Cf. Lekvinadze 1961, 241; Braund 1994, 182; Lordkipanidze & Noneshvili 2002, 171; Gamkrelidze & Todua 2006, 91.
 - 8 In detail, see Braund 1994, 152-169.
 - 9 At the turn of the new era, Kolchis was in the *Pontus Polemoniacus* (Strab. 11.2.18), the latter being subject to the Romans. Nero was against Augustus' internal politics and after Claudius' timid steps he gave priority to an aggressive foreign doctrine directed towards the East. This led to an increase of Roman military forces in the region and disrupted the system of *clientelae*. *Pontus Polemoniacus* was abolished and together with Kolchis it became a part of the Empire in AD 63 (Suet. *Nero* 18).
 - 10 Lekvinadze 1969, 75-93.
 - 11 Speidel 1986, 657-660; Braund 1986, 31-49; Kiguradze et al. 1987, 88-92; Todua 2003, 12-17; Gamkrelidze & Todua 2006, 60; cf. Mitford 1977, 509; Crow 1986, 77).
 - 12 Melikišvili 1970, 544-548; Lordkipanidze 1989, 347-348.
 - 13 See Tac. *Hist.* 2.32; Kolendo 1977, 399-408.
 - 14 Braund 1986, 39-44.
 - 15 Melikišvili 1959, 354, 368.
 - 16 Melikišvili 1959, 354.
 - 17 Melikišvili 1959, 364-377; Gregory 1997, 11-34.
 - 18 D. Braund noticed that the fort at Apsaros was "perhaps inherited from Polemon" (Braund 1994, 178), but as yet there have not been found any materials of this period in or outside the fort.
 - 19 Plontke-Lüning & Geyer 2003, 28-30, figs 6-7; 2005, 139, figs. 10-11; Varshalomidze 2004, 141-142, fig. 1.
 - 20 Chalvaši 2002, 88, figs. 7.3, 16; Kakhidze et al. 2002a, 52.
 - 21 Ebralidze 2005, 94, fig. 4.
 - 22 Ebralidze 2005, 94, fig. 50.
 - 23 For further details, see Džaparidze 2002, 194; Shalikadze 2004, 88, figs. 10-14, 16-17, 20.
 - 24 Bosworth 1977, 228; Speidel 1986, 658-659; Lordkipanidze 1991, 131; Mamuladze et al. 2002, 33-39; Gamkrelidze & Todua 2006, 66; cf. Rowell 1937, 1327-1328; Mitford 1980, 1169-1170.
 - 25 C. 1,000 men, see Mamuladze et al. 2002, 37; Gamkrelidze & Todua 2006, 66.
 - 26 Arr. *Periplus* 11; see Bosworth 1993, 250-252; Plontke-Lüning 2005, 134.
 - 27 El'nickij 1938, 310-311; Speidel 1986, 658.

- 28 Speidel 1983, 657-658.
- 29 See Mamuladze et al. 2002, 35, figs. 1-2.
- 30 Mamuladze et al. 2002, 35-37, figs. 3-5; Plontke-Lüning 2003, 12; Plontke-Lüning & Geyer 2003, 27; Plonke-Lüning 2005, 135.
- 31 Zos. *Hist. Nova* 1.31; see also Luttwak 1976, 147.
- 32 Chalvaši & Kakhidze 2004, 147.
- 33 Like some other eastern provinces, it remained agrarian and social or economic difficulties did not play a significant role. Most aspects of its original material culture were preserved by the Romans, especially at the inland sites.
- 34 Not long ago a stamped brick inscribed *LEG*, was found among the ruins of a fort at Moedani village, on the right bank of the Supsa River. 20 km distant from this site ruins of a quadrangular fort in Vašnari were discovered (Todua & Murvanidze 1997, 108-111; Sadradze 2003, 20-50). From this point of view, the 4th-century Shukhuti *villa*, the Ureki cemetery, and Onpareti and Khoreti *thermae* are interesting (Apakidze 1947, 89-111; Zakaraja & Lekvinadze 1966, 120-135; Sadradze et al. 1996, 31-32; 2001, 20-21, 27-28), as well as the Tsikhisdziri *villa* of the 5th-6th centuries (Inaishvili & Tavamaishvili 2001, 36). If we take all the recent archaeological findings into consideration, we will not be able to exclude the revival of Pičvnari during the 4th-5th centuries (Vickers & Kakhidze 2004, 209-214).
- 35 Vasilevskij 1909, 225-226; Qauchčišvili 1941, 57; Migne 1967, 221.
- 36 Some authors (Lekvinadze 1969, 82; Bryer & Winfield 1985, 325; Braund 1994, 265) believe that Apsaros may have been renamed Valentia, as is mentioned in the *Notitia dignitatum* (38.3), but most historians do not agree with this idea (Adonc 1971, 327; Lomouri 1975, 68; Zuckerman 1991, 532; Chalvaši & Kakhidze 2004, 148; Kakhidze 2005, 38-39; Plontke-Lüning 2003, 14, no. 87; 2005, 134).
- 37 Kekelidze 1961, 5-7.
- 38 Qauchčišvili 1955, 173,177, 203-204. In this connection, it is interesting that Procopius in describing the situation in the first half of the 6th century AD names an independent tribe obeying the Lazi bishops, neighboring the Trapezous district, and whose territory reached Sourmene and Rhizaeum (*De bello Gothico* 8.2.10-20). According to D. Braund this tribe was located between Rhizaeum (modern Rize) and Apsaros (Braund 1994, 279; cf. Gogitidze 2002, 23).
- 39 Chalvaši 2004, 148-149.
- 40 Chalvaši 2002, 88, fig. 7.3-11; Kakhidze et al. 2002b, 259-262; Fellmuth 2003, 44-46, 49-51; Ebralidze 2005, 94-95, figs. 4-32.
- 41 For further details, see Kakhidze et al. 2002b, 259; Varshalomidze 2004, 141-143, figs. 1-6.
- 42 Mamuladze et al. 2002, 261; Fellmuth 2003, 53-54; Shalikadze 2004, 88-89, figs. 10-20. Some samples were first found in Georgia, one of these bearing the Greek inscription ΛΑΒ/ETH/HNE/IKHN 'May you win' (Fig. 16.1). Another finely shaped Italian *krateriskos* is a rare find (Fig. 16.4).
- 43 Ebralidze 2005, 94, figs. 50-52, pl. 8.1-3. The bulk of the *louteria* brought to light at Apsaros are Sinopean wares. Two varieties of one type are identifiable: *Louteria* of type I (Fig. 23) are rare in the eastern Black Sea area. They have been discovered in layers of the end of the 1st century AD and the first half of the 2nd century AD. The *louteria* of type II (Fig. 24), dated to the 2nd-3rd centuries, were obviously widespread. At Apsaros Herakleian *louteria* of the 2nd-3rd centuries AD are found as well (Fig. 25).

- 44 Plontke-Lüning et al. 2002, 88-92; Fellmuth 2003, 51-52; Kakhidze & Mamuladze 2004, 47-59, figs. 30-41; Aslanishvili 2004, 152-154, figs. 1-5.
- 45 Lordkipanidze et al. 1980, 58-77; 2001, 20; Miron & Orthman 1995, 303.
- 46 For further details, see Mamuladze et al. 2001, 39; Kakhidze et al. 2002a, 50-70; Kakhidze et al. 2002b, 255-257; Khalvashi 2002a, 142-167).
- 47 Kakhidze et al. 2002a, 52, pl. 16.1-2; 2002b, 255-257; Chalvaši 2002, 88, pls. 3-4.
- 48 Chalvaši 2002, 88, fig. 7.1-2.
- 49 Ebralidze 2005, 94-95, fig. 53.
- 50 Kakhidze et al. 2002a, 53; Kakhidze & Mamuladze 2004, 54, figs. 23-25.
- 51 Local municipality and settlement in Apsaros used to play the same role as civilian settlements of Roman military units used to do elsewhere. In the forts of Pityous and Phasis a small trade workshop type – *vicus* settlements used to inhabit. The area of their function covered only coastal frontier (Gamkrelidze & Todua 2006, 89).
- 52 The provision of logistic support for the garrisons used to arrive by means of the central system from Trapezous in the 2nd-3rd centuries and from Antioch in the 4th century (for further details, see Gamkrelidze & Todua 2006, 112-113).
- 53 Gamkrelidze & Todua 2006, 111.
- 54 Todua 2003, 49-67.
- 55 The foreign power united Kolchis. This was the most important event of those times, an event that was to occur repeatedly during the following centuries.
- 56 Vasilevskij 1909, 226-227; for western literature, see Plontke-Lüning 2003, 15, no. 103; 2005, 135, no.18).
- 57 *Acta sanctorum* V, 694-696, 7th July; for a Georgian version, see Kekelidze 1957, 621.

Bibliography

- Adonc, N. 1971. *Armenia v epochu Iyustiniana*. Jerevan.
- Apakidze, A. 1947. Gvianantikuri chanis dzeglebi urekidan, *Saqartveloc mecnierrebata akademiis moambe* 14, 89-111.
- Aslanishvili, L. 2004. Stone missiles, in: Kachidze et al. (eds.) 2004, 152-155.
- Bosworth, A.B. 1977. Arrian and the Alani, *Harward Studies in Classical Philology* 81, 217-255.
- Bosworth, A.B. 1993. Arrian and Rome the minor works, in: ANRW II. 34.1.
- Braund, D. 1986. Caucasian frontier: myth, exploration and dynamics of imperialism in the defence of the Roman and Byzantine East, in: Freeman & Kennedy (eds.) 1986, 31-49.
- Braund, D. 1994. *Georgia in Antiquity. A History of Colchis and Transcaucasian Iberia 550 BC – AD 562*. Oxford.
- Bryer, A. & D. Winfield 1985. *The Byzantine Monuments and Topography of Pontus*. Vol. 1. Washington.
- Chalvaši, M. 2002. *Keramikuli tara Gonio-apsarosidan*. Batumi.
- Chalvaši, M. & E. Kachidze 2004. Apsarosi ach.ts. IV-V saukuneebši, *Dziebani* 13-14, 147-150.
- Crow, J. A. 1986. A review of the physical remains of the frontiers of Cappadocia, in: Freeman & Kennedy (eds.) 1986, 77-91.

- Djaparidze, V. 2002. Archäologische Arbeiten im Südbereich der Apsaros-Mauer, in: A. Gayer & S. Mamuladze (eds.), *Georgisch-Deutsche archäologische Expedition Gonio-Apsaros. Ester Vorläufiger Bericht. Arbeiten im Jahr 2000*. Tbilisi, 191-206.
- Džaparidze, V. 1998. Kolkhetis (Iazikis) safortifikacio nagebobebis šestsavlis akhali monacemebi da e.ts. pontos limesis sakitchi, in: *Abstracts of the Caucasus Archaeological Conference 1*. Tbilisi, 45-46.
- Džaparidze, V. 2000. Egrisis (Iazikis) adrebizantiuri qalaqebis arqeologiuri šestsavlis dziritadi sakitchebi, in: *Abstracts of the conference: Cities and Urban Life in the Ancient Georgia 2*. Tbilisi-Batumi, 36-42.
- Ebraldidze, T. 2005. *Samchret-dasavelet saqartvelos zghvispireti gvianelinistur da romaul chanaši*. Batumi.
- El'nickij, L.A. 1938. Iz istoričeskoj geografii drevnej Kolchidy, *VDI* 2, 307-320.
- Fellmuth, N. 2003. Zusammenstellung der Keramik- und Glasfunde aus den Schnitten des Jahres 2000 nördlich der Festung, in der Nordwestecke der Festung und im Bereich des modern Friedhofs, in: Geyer (ed.) 2003, 43-60.
- Freeman, P. & D. Kennedy (eds.) 1986. *The Defence of the Roman and Byzantine East. Proceedings of a Colloquium Held at University of Sheffield in 1986* (BAR International Series, 297.1). Oxford.
- Gamkrelidze, G. & T. Todua 2006. *Romis samchedro-politikuri eqspansia saqartveloči*. Tbilisi.
- Geyer, A. (ed.) 2003. *Neue Forschungen in Apsaros (2000-2002)*. Tbilisi.
- Geyer, A. & S. Mamuladze (eds.) 2002. *Gonio-Apsaros 3*. Iblisi.
- Gogitidze, S. 2002. *Samchret-dasaveleti saqartvelos saistorio geografia*. Batumi.
- Gregory, S. 1997. *Roman Military Architecture on the Eastern Frontier, 2*. Amsterdam.
- Inaishvili, N. & G. Tavamaishvili 2001. Tsikhisdziri Villa, in: *Abstracts of the 2nd International Congress on Black Sea Antiquities*. Ankara, 36.
- Kachidze, A. et al. (eds.) 2004. *Gonio-Apsarus*. Vol. 4. Batumi.
- Kachidze, E. 2005. Istoriuli tzaneti gvianantikur da adrebizantiur chana chanaši, *Activities of the N. Berdenishvili Batumi Rresearch Institute* 4, 36-45.
- Kakhidze, A. et al. 2002a. Arbeiten vor dem Südtor, in: Gayer & Mamuladze (eds.) 2002, 50-70.
- Kakhidze, A. et al. 2002b. The Recent Finds in Apsarus, in: M. Faudot, A. Fraysse & É. Geny (eds.), *Pont-Euxin et commerce: la genèse de la 'Route de la Soie.'* *Actes du IXe Symposium de Vani (Colchide) – 1999*. Paris, 251-262.
- Kakhidze, A. & S. Mamuladze 2004. The basic results of the studies carried out on the territory of the southern gate and baths block, in: Kachidze et al. (eds.) 2004, 4-68.
- Kekelidze, K. 1957. *Etiudebi dzveli qartuli literaturis istoriidan* 4. Tbilisi.
- Kekelidze, K. 1961. *Etiudebi dzveli qartuli literaturis istoriidan* 7. Tbilisi.

- Khalvashi, M. 2002. Arbeiten im Zentralbereich der Festung, in: Gayer & Mamuladze (eds.) 2002, 142-167.
- Kiguradze, N. et al. 1987. Klejma XV legiona iz Picundskogo gorodišča, *VDI* 2, 88-92.
- Kolendo, J. 1977. Le Recrutement des Legions au Temps de Néron et la Création de la Legio I Italica, in: J. Fitz (ed.), *Akten des XI Internationalen Limeskongresses*. Budapest, 399-408.
- Lekvinadze, V.A. 1961. Materialy po istorii i arhitekture Apsarskoj kreposti, *Vizantijskij vremennik* 20, 225-242.
- Lekvinadze, V.A. 1969. Pontijskij Limes, *VDI* 2, 75-93.
- Lomouri, N. 1975. Notitia Dignatitumis zogierti cnobis garkvevisatvis, *Activities of the Tbilisi State University* 162, 65-78.
- Lordkipanidze, G. 1991. *Bichvintis naqalaqari*. Tbilisi.
- Lordkipanidze, G. & A. Noneshvili 2002. Arbeiten im Turm 2, in: Gayer & Mamuladze (eds.) 2002, 171-183.
- Lordkipanidze, O. 1989. *Nasledie drevnej Gruzii*. Tbilisi.
- Lordkipanidze, O. 2001. Georgien – Land und Raum, in: I. Gambashidze & A. Hauptman (eds.), *Katalog der Ausstellung des Deutschen Bergbau-Museums Bochum in Verbindung mit dem Zentrum für Archäologische Forschungen der Georgischen Akademie der Wissenschaften Tbilissi vom 28. Oktober 2001 bis 19. Mai 2002*. Bochum, 2-53.
- Lordkipanidze, O. et al. 1980. *Gonios Gandzi*. Tbilisi.
- Luttwak, E.N. 1976. *The Grand Strategy of the Roman Empire*. London.
- Mamuladze, S. et al. 2001. Die Römer in Südwestgeorgien, *Georgica* 24, 35-46.
- Mamuladze, S. et al. 2002. Rimskie garnizony Apsara, *VDI* 1, 33-39.
- Melikišvili, G.A. 1959. *K istorii drevnej Gruzii*. Tbilisi.
- Melikišvili, G.A. 1970. Sakartvelo akh. ts. I-III saukuneebši, in: *Sakartvelos istoriis narkovevebi* 1. Tbilisi, 500-569.
- Migne, J. P. 1967. *Patrologia Graeca* 120. Paris.
- Miller, K. 1916. *Itineraria Romana*. Stuttgart.
- Miron, A. & W. Orthman (eds.) 1995. *Unterwegs zum Goldenen Vlies. Archäologische Funde aus Georgien*. Saarbrücken.
- Mitford, T.B. 1974. Some Inscriptions from the Cappadocian Limes, *JRS* 64, 160-175.
- Mitford, T.B. 1977. The Euphrates frontier in Cappadocia, in: *Studien zu Militärgrenzen Roms II* (10. Internationalen Limeskongress 1974). Köln-Bonn, 501-510.
- Mitford, T.B. 1980. Cappadocia and Armenia Minor: historical setting of the limes, in: *ANRW II.7.2*, 1169-1228.
- Plontke-Lüning, A. et al. 2002. Arbeiten in der Nordwestecke der Festung, nördlich der Festung und im Bereich des modernen Friedhofs, in: Gayer & Mamuladze (eds.) 2002, 87-97.
- Plontke-Lüning, A. 2003. Apsaros: Quellen und Geschichte, in: Geyer (ed.) 2003, 7-16.

- Plontke-Lüning, A. & A. Geyer 2003. Archäologische und naturwissenschaftliche Arbeiten in Apsaros in den Jahren 2000 bis 2002, in: Geyer (ed.) 2003, 17-34.
- Plontke-Lüning, A. 2005. Neue Forschungen in Apsaros (1.-8. Jh. n.Chr.), *Metalla* 12. 1/2, 133-145.
- Rowell, H.T. 1937. Numerus, in: *RE* 17, 1327-1330.
- Qauchčišvili, S. (ed.). 1941. *Georgica: Scriptorum Byzantinorum Excepta ad Georgian Pertinentia*. Vol. 4.1. Tbilisi.
- Qauchčišvili, S. (ed.). 1955. *Kartlis tschovreba* 1. Tbilisi.
- Sadradze, V. et al. 1996. Arqeologiuri kvleva-dzieba guriachi, 1991-1994 tslebshi, in: A. Apakidze (ed.), *Guria* 1. Tbilisi, 22-40.
- Sadradze, V. et al. 2001. Arqeologiuri kvleva-dzieba guriachi, 1997-1998 tslebshi, in: V. Sadradze (ed.), *Guria* 3. Tbilisi, 3-31.
- Sadradze, V. 2003. *Vašnari-sponieti-guriani*. Tbilisi.
- Shalikadze, T. 2004. *Gvianantikuri da adrešuasaukuneebis minis natsarmi samchret-dasavlet saqartvelos šavizghvispiretidan*. Batumi.
- Speidel, M. P. 1986. The Caucasus frontier: Second-century garrisons at Apsarus, Petra and Phasis, in: *Studien zu den Militärgrenzen Roms III* (13. Internationaler Limeskongress, Aalen 1983). Stuttgart, 657-660.
- Todua, T. & B. Murvanidze 1997. Romauli legionis tvifriani aguri sof. Moednidan, in: V. Sadradze (ed.), *Guria* 2. Tbilisi, 108-114.
- Todua, T. 2003. *Romauli samqharo da saqartvelos šavizghvispireti*. Tbilisi.
- Varshalomidze, I. 2004. Coins discovered at the southern gate, in: Kachidze et al. (eds.) 2004, 141-151.
- Vasilevskij, V.G. 1909. Choždenie apostola Andreja v stranu mirmidonjan, in: V.G. Vasilevskij, *Trudy* 2.1. St Peterburg, 213-295.
- Vickers, M. & A. Kakhidze 2004. *Pichvnari 1: Results of Excavations Conducted by the Joint British-Georgian Expedition 1998-2002*. Oxford-Batumi.
- Zakaraja, P.P. & V.A. Lekvinadze, 1966. Archeologičeskie raskopki v Šuchuti, *Matsne* 1, 120-135.
- Zuckerman, C. 1991. The early Byzantine strongholds in eastern Pontus, *Travaux et mémoires* 11, 527-553.

Abbreviations

ANRW *Aufstieg und Niedergang der römischen Welt.*